

# 12" DOUBLE BEVEL SLIDE COMPOUND MITRE SAW WITH TWIN LASER GUIDE

(Model Fox F36-259DB 110V)

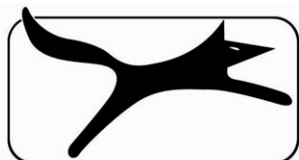

NOTICE D'UTILISATION / ASSEMBLY AND OPERATING INSTRUCTIONS



# FOX<sup>®</sup>

## GENERAL SAFETY INSTRUCTIONS

**VOLTAGE WARNING :** Before connecting the tool to a power source (receptacle, outlet, etc.) be sure the voltage supplied is the same as that specified on the nameplate of the tool. A power source with voltage greater than that for the specified tool can result in **SERIOUS INJURY** to the user - as well as damage to the tool. If in doubt **DO NOT PLUG IN THE TOOL**. Using a power source with voltage less is harmful to the motor.

### 1. KNOW YOUR TOOL

Read and understand the owner manual and labels affixed to the tool. Learn its application and limitation.

### 2. GROUND THE TOOL.

This tool is equipped with an approved 3-conductor cord and a 3-prong grounding type plug to fit the proper grounding type receptacle. The green conductor in the cord is the grounding wire. **NEVER** connect the green wire to a live terminal.

### 3. KEEP GUARDS IN PLACE.

Keep in good working order, properly adjusted and aligned.

### 4. REMOVE ADJUSTING KEYS AND WRENCHES.

Form habit of checking to see that keys and adjusting wrenches are removed from tool before turning it on.

### 5. KEEP WORK AREA CLEAN.

Cluttered areas and benches invite accidents. Make sure the floor is clean and not slippery due to wax and sawdust build-up.

### 6. AVOID DANGEROUS ENVIRONMENT.

Don't use power tools in damp or wet locations or expose them to rain. Keep work area well lit and provide adequate surrounding work space.

### 7. KEEP CHILDREN AWAY.

All visitors should be kept a safe distance from work area.

### 8. MAKE WORKSHOP CHILD-PROOF.

Use padlocks, master switches or remove starter keys.

### 9. USE PROPER SPEED.

A tool will do a better and safer job when operated at the proper speed.

### 10. USE RIGHT TOOL.

Don't force the tool or the attachment to do a job for which it was not designed.

### 11. WEAR PROPER APPAREL.

Do not wear loose clothing, gloves, neckties or jewelry (rings, watch) because they could get caught in moving parts. Non-slip footwear is recommended. Wear protective hair covering to contain long hair. Roll up long sleeves above the elbows.

### 12. ALWAYS WEAR SAFETY GLASSES.

Always wear safety glasses . Everyday eyeglasses only have impact resistant lenses, they are **NOT** safety glasses. Also use a face or dust mask if cutting operation is dusty.

### 13. DON'T OVERREACH.

Keep proper footing and balance at all times.

**14. MAINTAIN TOOL WITH CARE.**

Keep tools sharp and clean for best and safest performance. Follow instructions for lubricating and changing accessories.

**15. DISCONNECT TOOLS.**

Before servicing, when changing accessories or attachments.

**16. AVOID ACCIDENTAL STARTING.**

Make sure the switch is in the "OFF" position before plugging in.

**17. USE RECOMMENDED ACCESSORIES.**

Consult the manual for recommended accessories. Follow the instructions that accompany the accessories. The use of improper accessories may cause hazards.

**18. NEVER STAND ON TOOL.**

Serious injury could occur if the tool tips over. Do not store materials such that it is necessary to stand on the tool to reach them.

**19. CHECK DAMAGED PARTS.**

Before further use of the tool, a guard or other parts that are damaged should be carefully checked to ensure that they will operate properly and perform their intended function. Check for alignment of moving parts, breakage of parts, mounting, and any other conditions that may affect its operation. A guard or other parts that are damaged should be properly repaired or replaced.

**20. NEVER LEAVE MACHINE RUNNING UNATTENDED.**

Turn power "OFF". Don't leave any tool running until it comes to a complete stop.

**ADDITIONAL SAFETY INSTRUCTIONS FOR SLIDING COMPOUND  
MITER SAWS**

**1. WARNING: USE ONLY CROSS-CUTTING SAW BLADES. WHEN USING CARBIDE TIPPED BLADES, DO NOT USE BLADES WITH DEEP GUILLETS AS THEY CAN DEFLECT AND CONTACT GUARD.**

**2. WARNING:** Do not operate the miter saw until it is completely assembled and installed according to the instructions.

**3. IF YOU ARE NOT** thoroughly familiar with the operation of compound miter saws, obtain advice from your supervisor, instructor or other qualified person.

**4. DO NOT** perform any operation freehand. Secure or clamp workpiece firmly against fence.

**5. WARNING:** Keep hands out of path of saw blade. If the workpiece you are cutting would cause your hand to be within 4" of the saw blade, the workpiece should be clamped in place before making cut.

**6. BE SURE** blade is sharp, runs freely and is free of vibration.

**7. ALLOW** the motor to come up to full speed before starting cut.

**8. KEEP** motor air slots clean and free of chips.

9. **ALWAYS MAKE SURE** all clamp handles are tight before cutting even if the table is positioned in one of the positive stops.
10. **BE SURE** blade and flanges are clean and that arbor bolt is tightened securely.
11. **ONLY USE** blade flanges specified for your saw.
12. **NEVER** use blades larger or smaller in diameter than 10".
13. **NEVER** apply lubricants to the blade when it is running.
14. **ALWAYS** check the blade for cracks or damage before operating. Replace cracked or damaged blade immediately.
15. **NEVER** use blades recommended for operation at less than 6000 RPM.
16. **USE** the blade guard at all times.
17. **ALWAYS** keep the lower blade guard in place and operating properly.
18. **NEVER** reach around or behind saw blade.
19. **MAKE SURE** blade is not contacting workpiece before switch is turned on.
20. **NEVER** lock the switch in the "ON" position.
21. **IMPORTANT:** After completing cut, release power switch and wait for coasting blade to stop before returning saw to raised position.
22. **TURN OFF** tool and wait for saw blade to stop before moving workpiece or changing settings.
23. **DO NOT** remove jammed or cut-off pieces until blade has stopped.
24. **NEVER** cut ferrous metals or masonry. 25. **NEVER** re-cut small pieces.
26. **PROVIDE** adequate support to the sides of the saw table for long workpieces.
27. **NEVER** use the miter saw in an area with flammable liquids or gases.
28. **NEVER** use solvents to clean plastic parts. Solvents could possibly dissolve or otherwise damage the material. Only a soft damp cloth should be used to clean plastic parts.
29. **DISCONNECT** power by unplugging tool before changing blade or servicing.
30. **DISCONNECT** saw from power source before leaving it.
31. **MAKE SURE** the work area is cleaned before leaving the machine

## ELECTRICAL CONNECTIONS

As received from the factory, your miter saw is ready to run for 110V operation.

**WARNING :** ALL ELECTRICAL CONNECTIONS MUST BE DONE BY A QUALIFIED ELECTRICIAN. FAILURE TO COMPLY MAY RESULT IN SERIOUS INJURY! ALL ADJUSTMENTS OR REPAIRS MUST BE DONE WITH THE MITER SAW DISCONNECTED FROM THE POWER SOURCE. FAILURE TO COMPLY MAY RESULT IN SERIOUS INJURY!

### POWER SUPPLY

**WARNING:** YOUR MITER SAW MUST BE CONNECTED TO A 110V, 15-AMP. BRANCH CIRCUIT. FAILURE TO CONNECT IN THIS WAY CAN RESULT IN INJURY FROM SHOCK OR FIRE.

## SPECIFICATIONS

Voltage	110V ~ 50 Hz
Input power	1500W
No load speed	2850 RPM
Blade size	12" x 30 x 3,2 (60 teeth)
Arbor size	30mm
Miter table angles	0°, 15°, 22.5°, 30°, 45° left and right
Crosscut 90°	105 x 340 mm
Miter 45° (right & left)	105 x 240 mm
Bevel 45° (right)	40 x 340 mm
Bevel 45° (left)	65 x 340 mm
Compound (Miter & Bevel 45° right)	40 x 340 mm
Compound (Miter & Bevel 45° left)	65 x 240mm
Laser	Class II (EN 60825-1: 2007)
Net weight	23 kg
Brut weight	25 kg
Product dimensions :	835 × 570 × 790 mm
Packing dimensions :	915 × 570 × 535 mm

## UNPACKING AND ASSEMBLY

If you find anything wrong, do not operate the tool until the parts have been replaced or the fault has been rectified. Failure to do so could result in serious personal injury.

1. Remove all loose parts from the carton.
2. Remove the packing materials from around the saw.
3. Carefully lift the saw from the carton and place it on a level work surface.
4. The saw has been shipped with the saw arm locked in the down position. To release the saw arm, push down on the top of the saw arm, pull then turn the the saw head release knob (A) Fig.3.



Figure 3

**WARNING:** Do not lift the saw while holding on to the guards. Use the top mounted carrying handle.

### MITER TABLE POSITIVE STOPS

There are positive stops at 0°, 15°, 22.5°, 30° and 45° to the left and right. While the table is being rotated, the table will stop at the next positive stop. Once the desired angle is obtained, use the miter lock handle to lock the table.

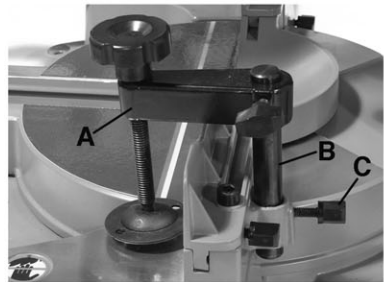

Figure 4

### WISE ASSEMBLIES (VERTICAL & HORIZONTAL)

The vertical vise (A) Fig.4 can be installed in two positions on either the left or right side of the guide fence. Insert the vise rod (B) into the hole in the guide fence and tighten the vise lock knob (C) to secure the vise rod.

The horizontal quick adjust vise (A) Fig.5 can be installed in two positions on either the left or right side of the table base. Insert the vise pivot shaft into the hole in the base as shown. To adjust the position of the vise, simply turn the handle or use the quick adjust feature by lifting the half nut (B) and pushing or pulling the handle to position the vise. Reposition the half nut on the threaded shaft to secure the vise in place.

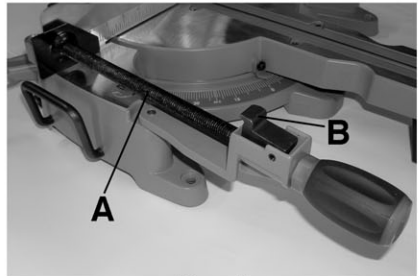

Figure 5

### PULLING OUT RETRACTABLE EXTENSION WINGS

If additional support is needed, it is high recommended to pull out the retractable extension wings (A) Fig.6, unlock knob (B), pull out extension wing and secure it in place by tightening the lock knob (B). Repeat for other side.

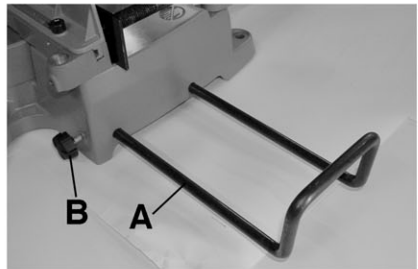

Figure 6

## ASSEMBLY & ADJUSTEMENTS

### REAR SUPPORT EXTENSION

This miter saw comes with a rear support extension (A) Fig.7. It increases stability and if the saw head is released unexpectedly, it will prevent the miter saw from tipping backwards.

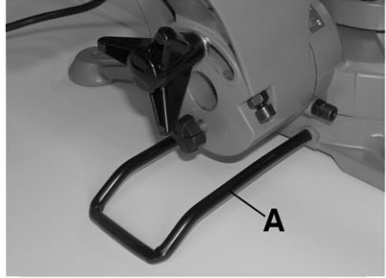

Figure 7

### DUST BAG

The dust bag (A) Fig.8 fits over the dust bag adaptor (B) at the rear of the saw head. For more efficient operation, empty the dust bag when it is no more than half full. This allows better air flow through the bag.

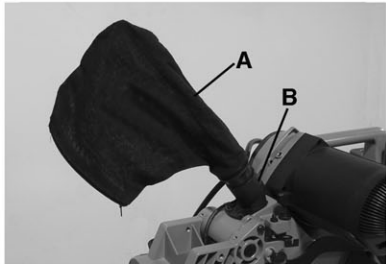

Figure 8

### BENCH MOUNTING

The saw base has holes to facilitate bench mounting.

1. Fix the saw to a bench using 4 hex. bolts and hex. nuts.
2. If desired, you can mount the saw to a piece of 13mm or thicker plywood which can then be clamped to your work support or moved to other job sites and reclamped.

**CAUTION:** Make sure that the mounting surface is not warped as an uneven surface can cause binding and inaccurate sawing.

### ADJUSTING FENCE EXTENSIONS

This miter saw comes with a back fence with fence extensions (A) Fig.9 at both ends which slide outwards for additional back support for those long workpieces. To adjust the position of each fence extension;

1. Loosen the fence extension cap screw (B) using supplied hex. key.
2. Loosen the fence extension rear lock knob (C).
3. Slide the fence extension outwards to the desired position and retighten the cap screw and rear lock knob.

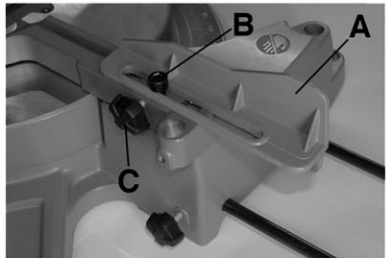

Figure 9

### DEPTH OF CUT STOP ADJUSTMENT



Figure 10

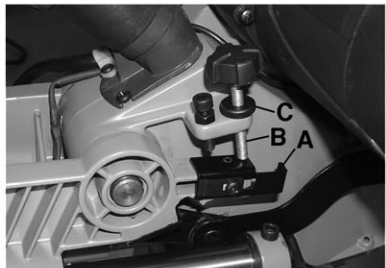

Figure 11

In its normal position, the depth of cut stop Fig.10 permits the saw blade to cut right through a workpiece. When the saw arm is lifted, the depth of cut stop (A) Fig.11 can be pushed towards the front of the saw so that the depth adjustment screw (B) contacts the stop as the saw arm is lowered.

This restricts the cut to a “adjusted depth” in the workpiece. The depth of cut can be adjusted with the adjustment screw and locked in position with the lock nut (C).

## ADJUSTMENTS

### ADJUSTING BEVEL ANGLE

This miter saw is capable of dual bevel angles which means the saw head can be inclined towards the right or the left. To adjust the saw head to any bevel angle;

1. Loosen the bevel lock knob (A) Fig.12 and pull the positive stop adjustment knob (B) outwards as shown. At this point, the saw head can be inclined to any angle you desire. If you require a predetermined bevel angle of 0°, push the adjustment knob inwards and pivot the saw head until it stops at 0°. Once the desired bevel angle is obtained, it is very important that you retighten the bevel lock knob (A).



Figure 12

### SETTING THE BLADE SQUARE WITH THE TABLE

1. Make sure that the electrical plug is removed from the main power supply.
2. Push the saw head down to its lowest position, then pull and turn the head release knob to hold the saw head in the transport position.
3. Loosen the miter lock handle.
4. Rotate the table until the pointer is positioned at 0°.
5. Retighten the miter lock handle.
6. Loosen the bevel lock knob at the rear of the machine and set the saw arm at 0° bevel (the blade at 90° to the miter table). Tighten the bevel lock knob.
7. Place a square against the table and the flat part of the blade.

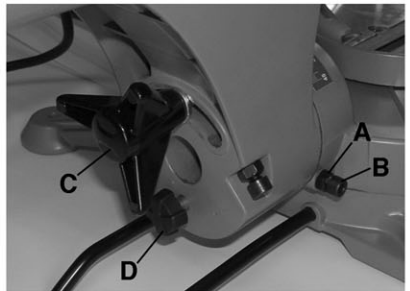

Figure 13

**NOTE:** Make sure that the square contacts the flat part of the saw blade, not the teeth.

8. Rotate the blade by hand and check the blade-to-table alignment at several points.
9. The edge of the square and the saw blade should be parallel.
10. If the saw blade angles away from the square, adjust as follows;

11. Loosen the two hex. nuts (A) Fig.13 on both sides of the bevel pivot which secure the two bevel adjustment cap screws (B), loosen the bevel lock knob (C) and pull the positive stop adjustment knob (D) outwards.
12. Adjust the bevel adjustment cap screws in or out to bring the saw blade into alignment with the square.
13. Retighten the bevel lock knob and hex. nuts. Recheck the alignment.
14. Readjust bevel pointer to line up with the 0° on the bevel scale.



Figure 14



## SETTING THE FENCE SQUARE WITH THE BLADE

1. Make sure that the electrical plug is removed from the main power supply.
2. Push the saw head down to its lowest position, then pull and turn the head release knob to hold the saw head in the transport position.
3. Loosen the miter lock handle.
4. Rotate the table until the pointer is positioned at 0°.
5. Retighten the miter lock handle.
6. Loosen the bevel lock knob at the rear of the machine and set the saw arm at 0° bevel (the blade at 90° to the miter table). Tighten the bevel lock knob.
7. Place a square against the fence and the flat part of the blade.

**NOTE:** Make sure that the square contacts the flat part of the saw blade, not the teeth.

8. The edge of the square and the fence should be parallel.
9. If the fence angles away from the square, adjust as follows;
10. Remove the fence extension cap screws, loosen the rear fence extension lock knobs and remove fence extensions by sliding them off the fence. Loosen the fence cap screws (A) Fig.14 on both sides and position the fence against the square and retighten all cap screws.
11. Reinstall fence extensions.

## ADJUSTMENTS & OPERATIONS

### USING THE TWIN LASER GUIDE SYSTEM

The twin laser guide system is controlled by the laser guide switch (A) Fig.15 and will only turn on when the miter saw is plugged into a power source.

**Warning! Do not stare directly into the laser beams.**

1. Mark the line of the cut on the workpiece.
2. Adjust the miter and/or bevel angles as required.
3. Before clamping the workpiece in position using the vertical or the horizontal vise, align the line of cut on the workpiece with the laser guide beam on either side of the blade kerf.
4. Start the motor.
5. When the blade reaches its maximum speed (approx. 2 sec.), lower the blade through the workpiece.

### ADJUSTING TWIN LASER GUIDE SYSTEM

If your laser guide does not seem to be aligned with both sides of the blade kerf, a small adjustment can be made.

1. Remove the laser guide protective plastic cover.
2. Loosen pan head screws (A) Fig.16 next to each laser guide (B).
3. Place a scrap piece of wood on the table and clamp it. Turn on miter saw and make a partial cut to indicate both sides of the blade kerf.
4. Turn both laser tips (B) until the laser beams are perfectly aligned with both sides of the blade kerf, once aligned, hold laser tip and retighten pan head screw (A) to prevent the laser dial from moving. Repeat for the second laser tip.

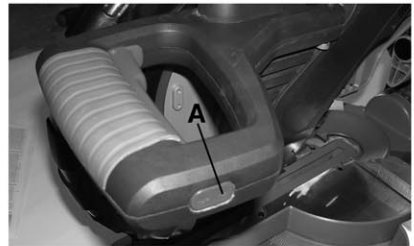

Figure 15

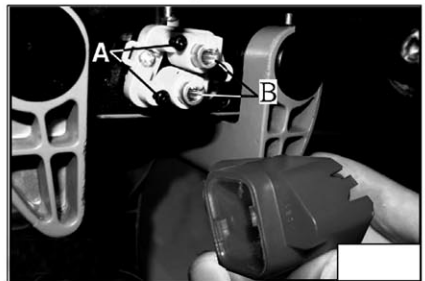

Figure 16

5. Reinstall the laser guide protective plastic cover.

### CUTTING OPERATIONS - CROSSCUTTING

When cutting a piece of wood it is not always necessary to use the slide mechanism. In these cases make sure that the slide lock knob (A) Fig.17 is locked to prevent the saw arm from sliding. A crosscut is made by cutting across the grain of the workpiece. A 90° crosscut is made with the miter and the bevel angles are set at 0°.

1. Pull and turn the saw head release knob (A) Fig.18 and lift the saw head to its full height.
2. Loosen the miter lock handle.
3. Rotate the miter table using miter handle until the pointer aligns with the 0°.
4. Retighten the miter lock handle.

**WARNING :** Be sure to tighten the miter lock handle before making a cut. Failure to do so could result in the table moving during the cut and cause serious personal injury.

6. Place the workpiece flat on the table with one edge securely against the fence.

If the board is warped, place the convex side against the fence. If the concave side is placed against the fence, the board could break and jam the blade.

7. When cutting long pieces of timber, support the opposite end of the timber with the extension wing or an additional roller stand or a work surface that is level with the saw table.
8. Use a vise or clamp to secure the workpiece whenever possible.
9. Before turning on the saw, perform a dry run of the cutting operation to check that there are no problems.
10. Hold the handle firmly and squeeze the trigger. Allow the blade to reach maximum speed.
11. Slowly lower the blade into and through the workpiece.
12. Release the switch trigger and allow the saw blade to stop rotating before raising the blade out of the workpiece. Wait until the blade stops before removing the workpiece.

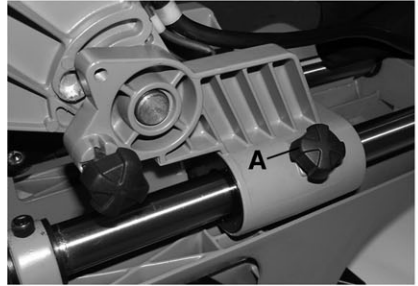

Figure 17



Figure 18

## OPERATIONS

**When cutting wide workpieces, you should use the sliding action, unlock the slide lock knob (A) Fig.17.**

1. Raise the saw head to its highest position and slide the blade towards you.
2. Hold the handle firmly and squeeze the trigger. Allow the blade to reach maximum speed.
3. Slowly lower the blade into the workpiece and slide it away from you at the same time until the workpiece is cut.
4. Release the switch trigger and allow the saw blade to stop rotating before raising the blade out of the workpiece. Wait until the blade stops before removing the workpiece.

### BEVEL CUT

A bevel cut is made by cutting across the grain of the workpiece with the blade angled to the fence and miter table. The miter table is set at the 0° position and the saw head is set at an angle between 0° and 45° to the right or left.

1. Pull and turn the saw head release knob (A) Fig.18 and lift the saw head to its full height.
2. Loosen the miter lock handle.
3. Rotate the miter table until the pointer aligns with zero on miter scale.
4. Retighten the miter lock handle.

**WARNING:** Be sure to tighten the miter lock handle before making a cut. Failure to do so could result in the table moving during the cut and serious personal injury.

5. Loosen the bevel lock knob, pull the positive stop bouton outwards and move the saw arm to the desired bevel angle (between 0° and 45° to the right of left). Retighten the bevel lock knob.
6. Place the workpiece flat on the table with one edge securely against the fence. If the board is warped, place the convex side against the fence.

If the concave side is placed against the fence, the board could break and jam the blade.

7. When cutting long pieces of timber, support the opposite end of the timber with the extension wings.
8. Use the vise to secure the workpiece whenever possible.
9. Before turning on the saw, perform a dry run of the cutting operation to check that there are no problems.
10. Hold the handle firmly and squeeze the trigger. Allow the blade to reach maximum speed.
11. Slowly lower the blade into and through the workpiece.
12. Release the switch trigger and allow the saw blade to stop rotating before raising the blade out of the workpiece. Wait until the blade stops before removing the workpiece.

### DUAL COMPOUND CUT

A dual compound cut involves using a miter angle and a bevel angle at the same time. It is used in making picture frames, to cut mouldings, making boxes with sloping sides and for roof framing. Always make a test cut on a piece of scrap wood before cutting into good material. Use the slide action when cutting wide workpieces, unlock slide by unscrewing lock knob (A) Fig.17.

1. Pull and turn the saw head release knob (A) Fig.18 and lift the saw head to its full height.
2. Loosen the miter lock handle.
3. Rotate the miter table until the pointer aligns with the desired angle on the miter scale.
4. Tighten the miter lock handle.

**Warning:** Be sure to tighten the miter lock knob before making a cut. Failure to do so could result in the table moving during the cut and serious personal injury.

5. Loosen the bevel lock knob (C) Fig.13 and move the saw arm to the left to the desired bevel angle (between 0° and 45°). Tighten the bevel lock knob.
6. Place the workpiece flat on the table with one edge securely against the fence. If the board is warped, place the convex side against the fence.
- If the concave side is placed against the fence, the board should break and jam the blade.
7. When cutting long pieces of wood, support the long pieces using the extension wings.
8. Use the vertical vise to secure the workpiece whenever possible.
9. Before turning on the saw, perform a dry run of the cutting operation to check that there are no problems.
10. Hold the handle firmly and squeeze the trigger. Allow the blade to reach maximum speed.
11. Slowly lower the blade into and through the workpiece.
12. Release the trigger and allow the saw blade to stop rotating before raising the blade out of the workpiece. Wait until the blade stops before moving the workpiece.

## REPLACING / INSTALLING BLADE & DRIVE BELT

### REPLACING/INSTALLING BLADE

#### **DANGER!**

- Never attempt to use a blade larger than the stated capacity of the saw (12"). It will come into contact with the blade guards.
- Never use a blade that is too thick to allow the outer blade flange to engage with the flats on the spindle. It will prevent the blade screw from properly securing the blade on the spindle.
- Do not use the saw to cut metal or masonry.

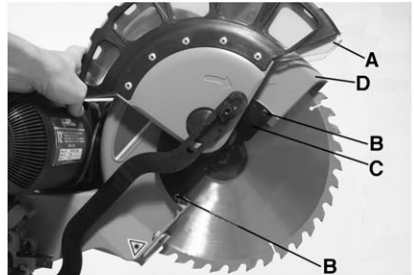

Figure 19

1. Make sure that the power cord is removed from the main power supply.
2. Push down on the saw arm and pull and turn the saw head release knob to disengage the saw head.
3. Raise the saw head to its highest position.
4. Lift the lower blade guard (A) Fig.19 with one hand, and with the other hand, unscrew and remove both pan hd screws (B) which fix the guard plate (C) and lower blade guard to the upper blade guard (D) using a Phillips screwdriver.
5. Pull the guard plate and lower blade guard downwards and set it all down on the table to allow access to the blade bolt.
6. Completely depress the spindle lock button (A) Fig. 20 using one hand. Rotate the blade by hand until the spindle locks.
7. Use the blade wrench (A) Fig.21 provided to remove the blade bolt (B), loosen in a clockwise direction as the blade bolt has a left hand thread.
8. Remove the outer blade flange (C) and the blade.
9. Wipe a drop of oil onto the inner and outer blade flanges.
10. Fit the new blade onto the spindle making sure that the inner blade flange sits properly behind the blade.

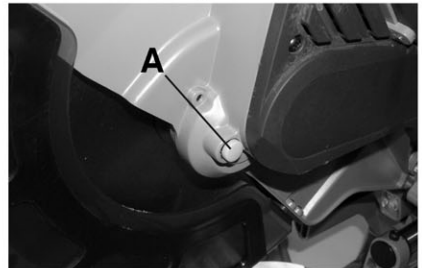

Figure 20

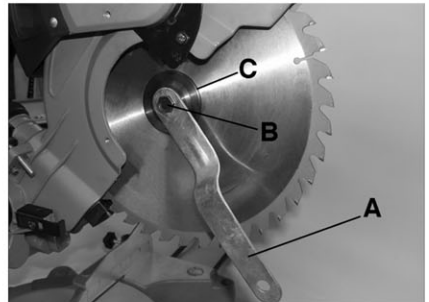
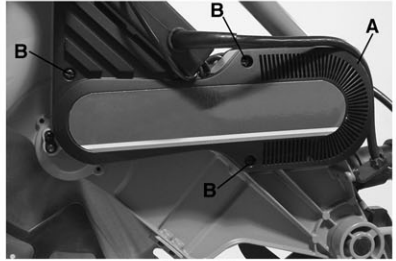

Figure 21

**CAUTION:** Always install the blade with the blade teeth pointing downwards. The direction of the blade rotation is also stamped with an arrow on the upper blade guard.

11. Reposition the outer blade flange.
12. Depress the spindle lock and reposition and secure the blade bolt using the blade wrench. Tighten the blade bolt in a counterclockwise direction as the blade bolt has a left hand thread).
13. Reposition the lower blade guard and guard plate and secure the guard plate with both pan hd screws removed in step 4.



**Figure 22**

### **REPLACING BELT & ADJUSTING BELT TENSION**

If the drive belt needs to be replaced or properly tensioned, follow these instructions;

1. Make sure that the power cord is removed from the main power supply.
2. Push down on the saw arm and pull and turn the saw head release knob to lock the saw arm in the down position.
3. Remove the drive belt cover (A) Fig.22 by removing the 3 pan hd screws (B).
4. To release the belt tension, first loosen the 6 pan hd screws (A) Fig.23 inside the belt housing to allow the motor to move position. Then unscrew the belt tension set screw (A) Fig.24 to release the belt tension.
5. Remove the used drive belt by hand.
6. Reposition new drive belt making sure the belt is properly centered on both pulleys.
7. Tighten the belt tension set screw until you obtain a 1/2" center deflection of the belt by applying pressure with your fingers.
8. Once the belt is properly tensioned, retighten the 6 pan hd screws (A) Fig.23.
9. Reposition the belt cover and secure it into place using the same 3 pan hd screws (A) Fig.22 removed previously



**Figure 23**

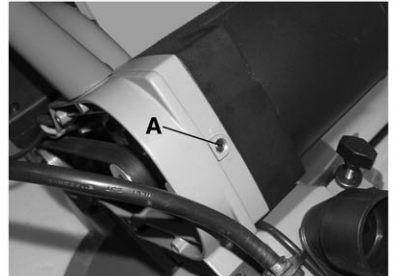

**Figure 24**

# MAINTENANCE

## MAINTENANCE

All the ball bearings are sealed and lubricated for life and will require no maintenance.

### Cleaning

- After use, wipe off chips and dust adhering to the tool with cloth or the like. Keep the blade guards and covers clean . Lubricate the sliding portions with machine oil to prevent rust. To maintain product SAFETY and RELIABILITY, repairs, any other maintenance or adjustment should be performed by your nearest authorized service center.

### REPLACING CARBON BRUSHES

Remove and check the carbon brushes regularly (normally after 50 hours of use). The carbon brushes are installed inside the motor housing. Using a screwdriver, remove the 2 pan head screws that hold the motor housing cap in place.

Once the motor housing cap is removed, to release the carbon brush (B) Fig.25 from the holder, lower the retaining spring (A). Disconnect the carbon brush wire (C) from the terminal, remove the carbon brush from the motor housing and inspect it. Repeat this step for the second carbon brush. Carbon brushes need to be replaced once they wear down to the limit mark, see Fig.26. Keep the carbon brushes clean and free to slip in the holders.

If they have worn down to the limit mark, purchase a set of identical replacement carbon brushes (both carbon brushes should be replaced at the same time). Insert new carbon brushes into the holders, connect them to the terminals, reposition the retaining spring and reinstall the motor housing cap using the 2 pan head screws.

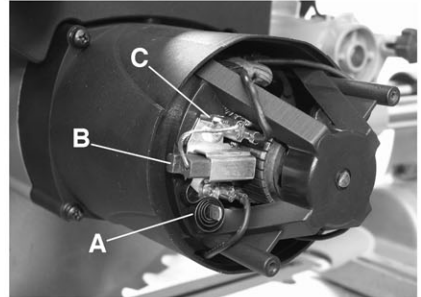

Figure 25

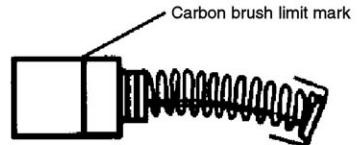

Figure 26

## AFTER-SALES SERVICE

All tools and accessories are made and checked by using the safest and most modern productive methods. However, if a tool gets damaged, it must be repaired by an authorised after sales centre.

You can call the phone number 01592652946 or by sending a request to the e-mail address [sales@serracon.co.uk](mailto:sales@serracon.co.uk).



**CE DECLARATION OF CONFORMITY OF THE MANUFACTURER**

SERRACON  
NEXUS HOUSE  
WHEATFIELD ROAD  
DUNNIKIER BUSINESS PARK  
KIRCALDY KY1 3PD ENGLAND  
Tel. +01592652946 - Fax +01592654854

Declares that the: MITRE SAW (F36-259DB 110V)

is in compliance with the regulations included in the Directives: CEE 2006/42-2004/108-2006/95

The Director  
Robert Paterson

A handwritten signature in black ink that reads "Robert Paterson".

---

The CE mark, consisting of the letters "C" and "E" in a stylized, bold font.

04.05.2011





**F36-259DB 110V**  
**TRONCATRICE RADIALE A DOPPIA INCLINAZIONE /**  
**DOUBLE BEVEL SLIDING MITRE SAW**

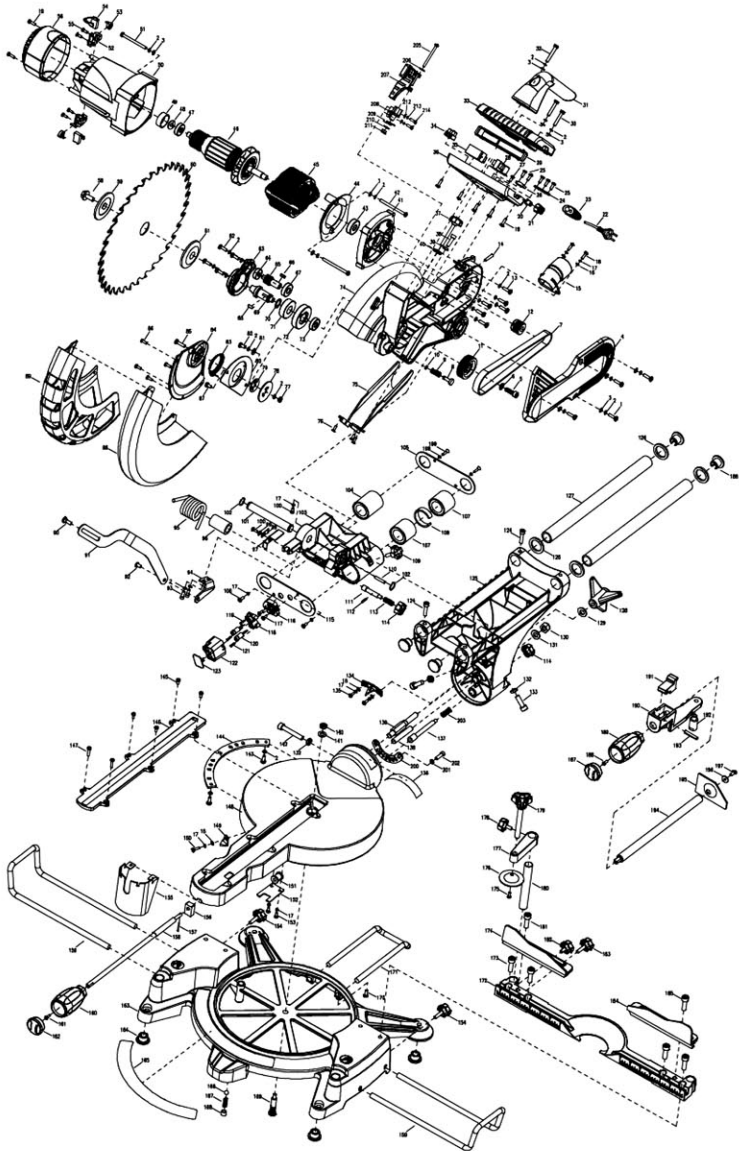



**F36-259DB 110V**  
**TRONCATRICE RADIALE A DOPPIA INCLINAZIONE /**  
**DOUBLE BEVEL SLIDING MITRE SAW / SCIE A ONGLET RADIALE**  
**A DOUBLE INCLINAISON**

1	F36259DB-1			113	F36259DB-113	169	F36259DB-169
2	F36259DB-2	58	F36259DB-58	114	F36259DB-114	170	F36259DB-170
3	F36259DB-3	59	F36259DB-59	115	F36259DB-115	171	F36259DB-171
4	F36259DB-4	60	F36259DB-60	116	F36259DB-116	172	F36259DB-172
5	F36259DB-5	61	F36259DB-61	117	F36259DB-117	173	F36259DB-173
6	F36259DB-6	62	F36259DB-62	118	F36259DB-118	174	F36259DB-174
7	F36259DB-7	63	F36259DB-63	119	F36259DB-119	175	F36259DB-175
8	F36259DB-8	64	F36259DB-64	120	F36259DB-120	176	F36259DB-176
9	F36259DB-9	65	F36259DB-65	121	F36259DB-121	177	F36259DB-177
10	F36259DB-10	66	F36259DB-66	122	F36259DB-122	178	F36259DB-178
11	F36259DB-11	67	F36259DB-67	123	F36259DB-123	179	F36259DB-179
12	F36259DB-12	68	F36259DB-68	124	F36259DB-124	180	F36259DB-180
13	F36259DB-13	69	F36259DB-69	125	F36259DB-125	181	F36259DB-181
14	F36259DB-14	70	F36259DB-70	126	F36259DB-126	182	F36259DB-182
15	F36259DB-15	71	F36259DB-71	127	F36259DB-127	183	F36259DB-183
16	F36259DB-16	72	F36259DB-72	128	F36259DB-128	184	F36259DB-184
17	F36259DB-17	73	F36259DB-73	129	F36259DB-129	185	F36259DB-185
18	F36259DB-18	74	F36259DB-74	130	F36259DB-130	186	F36259DB-186
19	F36259DB-19	75	F36259DB-75	131	F36259DB-131	187	F36259DB-187
20	F36259DB-20	76	F36259DB-76	132	F36259DB-132	188	F36259DB-188
21	F36259DB-21	77	F36259DB-77	133	F36259DB-133	189	F36259DB-189
22	F36259DB-22	78	F36259DB-78	134	F36259DB-134	190	F36259DB-190
23	F36259DB-23	79	F36259DB-79	135	F36259DB-135	191	F36259DB-191
24	F36259DB-24	80	F36259DB-80	136	F36259DB-136	192	F36259DB-192
25	F36259DB-25	81	F36259DB-81	137	F36259DB-137	193	F36259DB-193
26	F36259DB-26	82	F36259DB-82	138	F36259DB-138	194	F36259DB-194
27	F36259DB-27	83	F36259DB-83	139	F36259DB-139	195	F36259DB-195
28	F36259DB-28	84	F36259DB-84	140	F36259DB-140	196	F36259DB-196
29	F36259DB-29	85	F36259DB-85	141	F36259DB-141	197	F36259DB-197
30	F36259DB-30	86	F36259DB-86	142	F36259DB-142	198	F36259DB-198
31	F36259DB-31	87	F36259DB-87	143	F36259DB-143	199	F36259DB-199
32	F36259DB-32	88	F36259DB-88	144	F36259DB-144	200	F36259DB-200
33	F36259DB-33	89	F36259DB-89	145	F36259DB-145	201	F36259DB-201
34	F36259DB-34	90	F36259DB-90	146	F36259DB-146	202	F36259DB-202
35	F36259DB-35	91	F36259DB-91	147	F36259DB-147	203	F36259DB-203
36	F36259DB-36	92	F36259DB-92	148	F36259DB-148		
37	F36259DB-37	93	F36259DB-93	149	F36259DB-149	205	F36259DB-205
38	F36259DB-38	94	F36259DB-94	150	F36259DB-150	206	F36259DB-206
39	F36259DB-39	95	F36259DB-95	151	F36259DB-151	207	F36259DB-207
40	F36259DB-40	96	F36259DB-96	152	F36259DB-152	208	F36259DB-208
41	F36259DB-41	97	F36259DB-97	153	F36259DB-153	209	F36259DB-209
42	F36259DB-42	98	F36259DB-98	154	F36259DB-154	210	F36259DB-210
43	F36259DB-43	99	F36259DB-99	155	F36259DB-155	211	F36259DB-211
44	F36259DB-44	100	F36259DB-100	156	F36259DB-156	212	F36259DB-212
45	F36259DB-45	101	F36259DB-101	157	F36259DB-157	213	F36259DB-213
46	F36259DB-46	102	F36259DB-102	158	F36259DB-158	214	F36259DB-214
47	F36259DB-47	103	F36259DB-103	159	F36259DB-159		
48	F36259DB-48	104	F36259DB-104	160	F36259DB-160		
49	F36259DB-49	105	F36259DB-105	161	F36259DB-161		
50	F36259DB-50	106	F36259DB-106	162	F36259DB-162		
51	F36259DB-51	107	F36259DB-107	163	F36259DB-163		
52	F36259DB-52	108	F36259DB-108	164	F36259DB-164		
53	F36259DB-53	109	F36259DB-109	165	F36259DB-165		
54	F36259DB-54	110	F36259DB-110	166	F36259DB-166		
55	F36259DB-55	111	F36259DB-111	167	F36259DB-167		
56	F36259DB-56	112	F36259DB-112	168	F36259DB-168		

SCHEMA ELETTRICO / WIRING DIAGRAM / SCHEMA ELECTRIQUE

